

WOOL AND THE GANG

#MADEUNIQUE

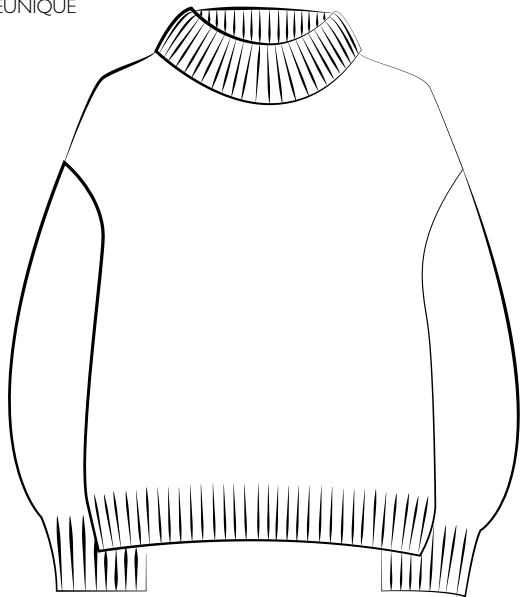

LET'S DO THIS SWEATER

INTERMEDIATE

12MM (US17) NEEDLES
15MM (US 19) NEEDLES

© Wool and the Gang LTD. 2017

YOUR ADVENTURE STARTS NOW

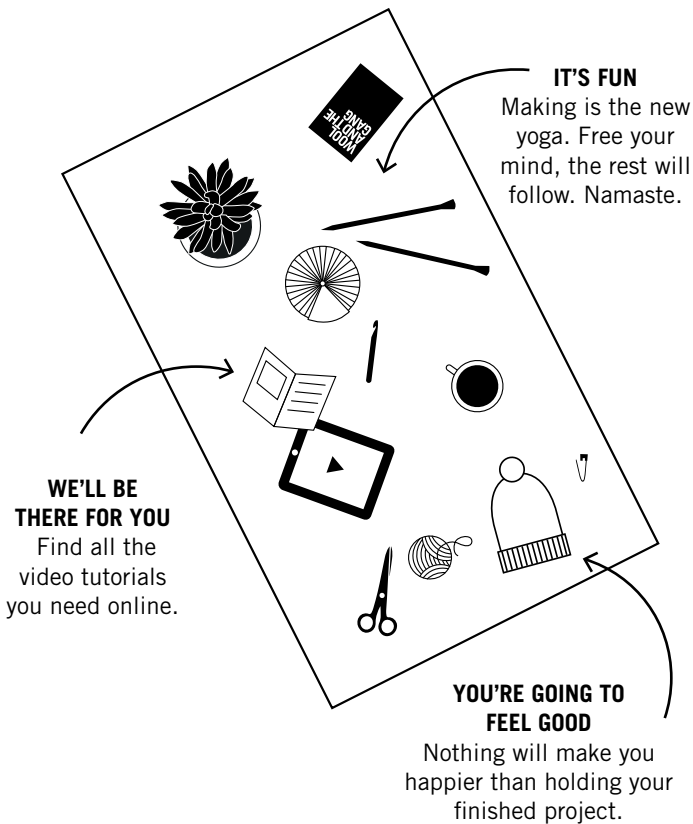

RECIPE FOR SUCCESS

1

GET YOUR TOOLS READY.

Everything you need to get making.

2

FAMILIARISE YOURSELF WITH THE TECHNIQUES.

Everything from the stitches used to the finishing touches for your project.

3

GET TO KNOW YOUR YARN.

Before you start your piece, play around with your new yarn to get used to it, and to check your tension.

4

WOOL SCHOOL

Pick up your needles & yarn and make the magic happen! For a little extra help, check out our Wool School at:

www.woolandthegang.com/t/how-to

5

#WOOLANDTHEGANG

When you're done - let the world know.

LET'S GET KNITTING

Tool kit

- 6 [6:7:8:8:9] balls of WATG's Crazy Sexy Wool
- 1 Let's Do This Sweater pattern
- 1 pair of 12mm (17US) knitting needles
- 1 pair of 15mm (19US) knitting needles
- 1 sewing needle

Tension

To ensure your knitting has the same measurements as the pattern, it is a good idea to make a tension swatch before you start knitting your project. A tension swatch is a small sample of your knitting where you count the stitches and rows and check them against the tension given in the pattern. If you get MORE stitches/rows than the pattern's tension, it means your knitting is tighter. If you get FEWER stitches/rows than the pattern, your knitting is looser. Sometimes, it works to knit tighter or looser to compensate.

1x1 rib stitch (12mm / US19)

10 cm/4" = 8 stitches

10 cm/4" = 10 rows

Stocking stitch (15mm / US19)

10 cm/4" = 6 stitches

10 cm/4" = 9 rows

All knitting techniques can be found at the back of the pattern.

SIZING

The pattern includes directions for 6 sizes. When the instructions differ between sizes, information is given for size 1 first, then for sizes 2 - 6 in brackets, separated by a colon. (example: size 1[size 2:size 3:size 4:size 5:size 6].)

You might want to highlight your size before you start knitting!

	SIZE 1	SIZE 2	SIZE 3	SIZE 4	SIZE 5	SIZE 6
TO FIT CHEST CM/”	80-86 / 32-34	88-96 / 36-38	100-108 / 40-42	112-118 / 44-46	122-128 / 48-50	132-140 / 52-54”
UK	6-8	10-12	14-16	18-20	22-24	26-28
US	2-4	6-8	10-12	14-16	18-20	22-24
EU	34-36	38-40	42-44	46-48	50-52	54-56
IT	38-40	42-44	46-48	50-52	54-56	58-60
AUS	6-8	10-12	14-16	18-20	22-24	26-28
ASIA	7-9	11-13	15-17	19-21	23-25	27-29

Pssst! Remember that you must not copy our patterns and sell, or even give them away for free, in accordance with copyright law.

MEASUREMENTS: SIZES 1 & 2

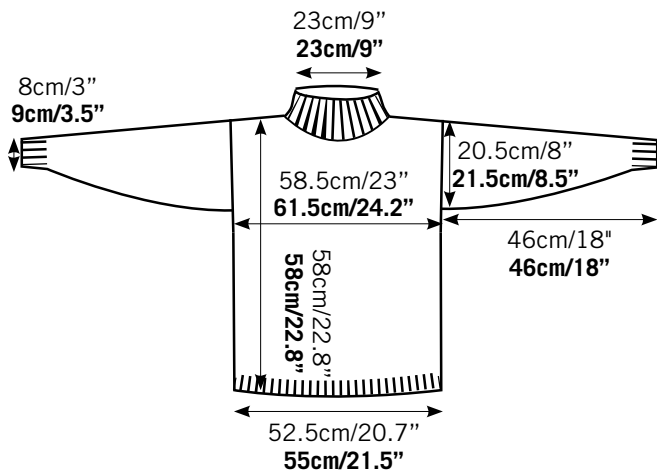

MEASUREMENTS: SIZES 3 & 4

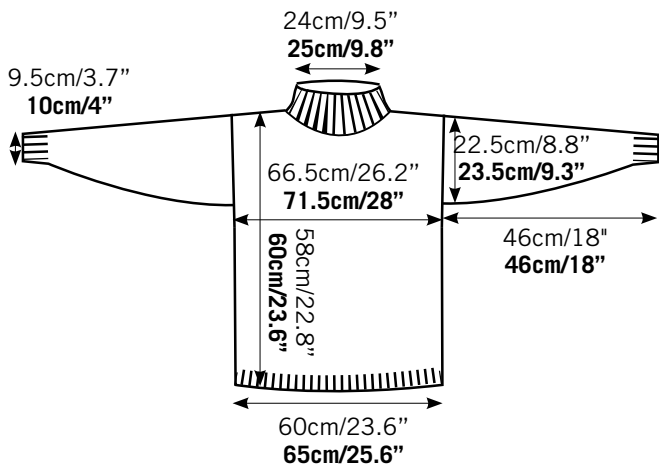

MEASUREMENTS: SIZES 5 & 6

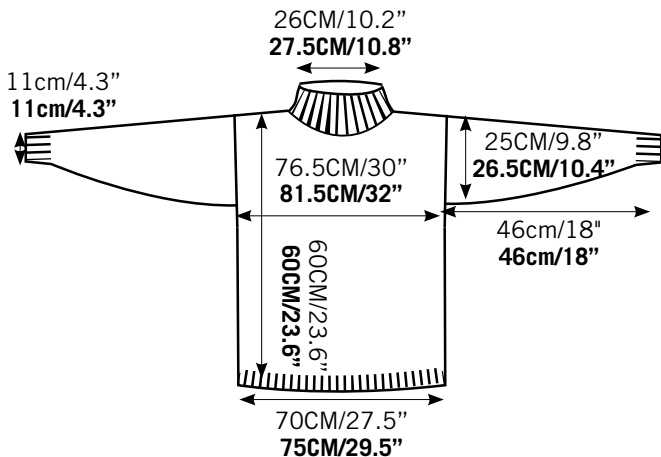

Help's only a stitch away. Watch the video tutorials online at www.woolandthegang.com/videos

HOW TO MAKE YOUR LET'S DO THIS SWEATER

The front and back pieces are knitted first and then seamed together. You will then pick up stitches along the neck to work the neckline ribbing. The sleeves are worked by picking up stitches from the body of your sweater and knitting outwards.

BACK

- 1 With 12mm (US17) needles, cast on 44[46:50:54:58:62] stitches, using the long-tail cast on technique.

- 2 Work in 1x1 rib stitch until your piece measures 6cm/2.4" from the cast on edge (approx. 5 rows).

- 3 **Decrease row:** Change to 15mm (US19) needles. Knit 1[3:1:8:7:6] stitch(es), ★make a right-leaning decrease, knit 4[4:4:3:3:3] stitches.★ Repeat the section inside the stars (★) a further 6[6:7:8:9:10] times. Knit 1 stitch. (37[39:42:45:48:51] stitches.)

- 4 Starting with a purl row work in stocking stitch until your piece measures 58cm/22.8" [58cm/22.8": 58cm/22.8": 60cm/23.6": 60cm/23.6": 60cm/23.6"] from the cast on edge (approx. a further 47[47:47:49:49:49] rows). Your last row should be a purl row.

- 5 Cast off.

FRONT

- 1 Work steps 1 to 3 as given for the back.

- 2 Starting with a purl row work in stocking stitch until your piece measures 53cm/20.8' [53cm/20.8": 53cm/20.8": 55cm/21.6": 55cm/21.6": 55cm/21.6"] from the cast on edge (approx. a further 43[43:43:45:45:45] rows). Your last row should be a purl row.

- 3 **Decrease row:** Knit 14[15:16:17:18:19] stitches, cast off 9[9:10:11:12:13] stitches, knit to the end of the row. (28[30:32:34:36:38] stitches.)

Next, you will be working across only half of your stitches – simply leave the rest of the stitches on the needle for now, you will come back to them later.

- 4 **Decrease row:** Purl 11[12:13:14:15:16] stitches, make a right-leaning purl decrease, purl the last stitch. (13[14:15:16:17:18] stitches.)

- 5 **Decrease row:** Knit 1 stitch, make a left-leaning decrease, knit to the end of the row. (12[13:14:15:16:17] stitches.)

- 6 Purl 1 row.
- 7 Cast off.

With the wrong side facing you, re-join the yarn to the stitches that have been waiting on your needle.

- 8 Decrease row:** Purl 1 stitch, make a left-leaning purl decrease, purl to the end of the row. (13[14:15:16:17:18] stitches.)
-
- 9 Decrease row:** Knit 10 [11:12:13:14:15] stitches, make a right-leaning decrease, knit the last stitch. (12[13:14:15:16:17] stitches.)
-
- 10** Purl 1 row.
-
- 11** Cast off.

ASSEMBLY & FINISHING

- 1 Place your front and back panels on top of each other, with the wrong sides touching.
- 2 Thread your sewing needle with a length of yarn. Starting at the outside edge, use the horizontal invisible seam technique to sew up the left shoulder seam.

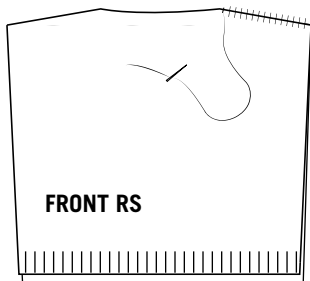

You will now create your neck.

- 3 Using your 12mm (US15) knitting needles, with the right side of the work facing you and working from right to left, pick up and knit 19[19:20:21:22:23] stitches along the back neck and 21[21:22:23:24:25] stitches along the front neck. (40[40:42:44:46:48] stitches.)
- 4 Work in 1x1 rib stitch until your neck measures 20cm/8" (approx. 19 rows.)
- 5 Cast off loosely in ribbing.

- 6** Now you have knitted your neck, thread your sewing needle with a length of yarn. Starting at the outside edge, use the horizontal invisible seam technique to sew up the right shoulder seam, then use the vertical invisible seam technique to sew the neck seam together for 8cm/3”.

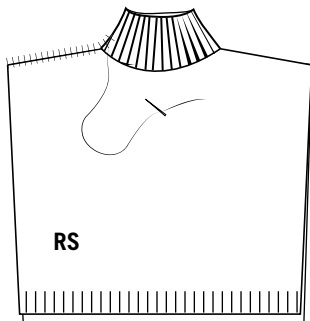

- 7** Turn your sweater so the wrong side is facing out, seam the rest of your neck using the vertical invisible seam technique.

Next, you will knit the sleeves.

- 8** Measure 22.5cm/8.9” [23.5cm/9.3”: 24cm/9.5”: 25cm/9.8”: 26.5cm/10.4”: 28.5cm/11” down each side of your jumper from the shoulder seam.
- 9** With 15mm (US19) needles, pick up and knit 27[28:29:30:32:34] stitches between these two points.

- 10** Work in stocking stitch until your sleeve measures 38cm/15" from the cast on edge. (Approx. a further 33 rows.) Your last row must be a purl row.
- 11** **Decrease row:** Change to 12mm (US17) needles. Work 2[2:2:2:4:2] stitches in 1x1 rib stitch, ★make a right-leaning decrease, make a left-leaning purl decrease.★ Repeat the section inside the stars until you have 1[2:3:4:4:4] stitch left of your row, work in 1x1 rib stitch to the end of the row. (15[16:17:18:20:20] stitches.)
- 12** Work in 1x1 rib stitch for 8cm/3". (Approx. a further 7 rows.)
- 13** Cast off in ribbing.
- 14** Repeat steps 8 to 13 for the other sleeve.

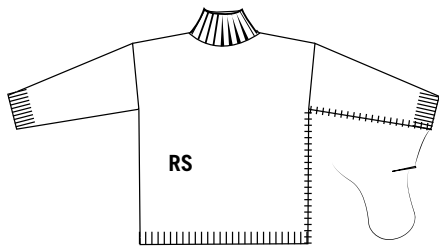

- 15** Finally, with the right side of the fabric facing you, use the vertical invisible seam technique to sew the sides of the front and back together, then continue and sew the sleeve seams.
- 16** Weave in any loose ends.

KNITTING TECHNIQUES



Help's only a stitch away. Watch the video tutorials online at www.woolandthegang.com/videos

Work! Work! Work!

There are two main ways to 'work' stitches: they can be knitted or purled. When the pattern asks you to 'work' a number of stitches/rows/cm, it will always specify which stitch pattern to work in.

Long-tail cast on

This creates a nice elastic edge, suitable for stretchy items like hats. To make sure that the edge isn't too tight, you can cast on over two knitting needles held together.

1. Start by making a slipknot - the 'yarn tail' needs to be quite long for this cast on, hence the name! Place the slipknot on your knitting needle, and hold the needle in your right hand, with the yarn hanging straight down.
2. Now insert the thumb and index finger of your left hand between the two strands of yarn hanging from the needle, and then close your ring finger and little finger around the yarn to trap it.

Stretch out your thumb and index finger as far from each other as possible, stretching the yarn taut.

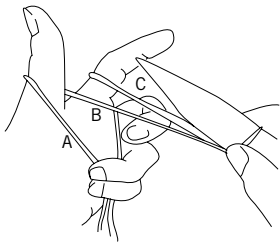

3. You will be using three separate strands of yarn:

A: the strand which sits closest to you, in front of the thumb

B: the strand that goes from the thumb to the slipknot on the needle

C: the strand that goes from the needle to your index finger

4. Place the needle in front of A, then bring it under A and let it come up between A and B.

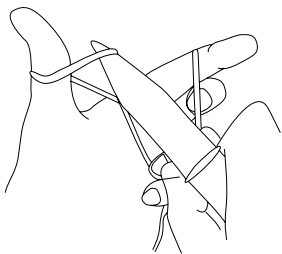

5. Now bring the needle over and behind C, and scoop the yarn (C) up with the tip of your needle.

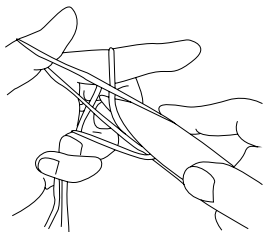

6. Bring the needle tip with the yarn back between A and B (the same way you came before), so that it ends up in front of A. Now pull your thumb out from the yarn that's looped around it. Tug on the yarn to tighten up the new loop on your knitting needle.

7. Repeat steps 2-6 to continue casting on stitches.

Stocking stitch / [▶ Online video tutorial](#)

A basic stitch pattern where you knit all the stitches of one row, then purl all the stitches of the next. These two rows are repeated to make the pattern. The 'right' side of the fabric looks like a series of 'Vs' and the 'wrong' side of the fabric looks like a series of 'waves'.

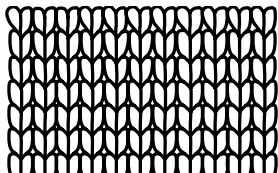

RIGHT SIDE

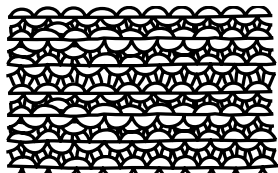

WRONG SIDE

1 x 1 Rib stitch / [▶ Online video tutorial](#)

When working over an uneven number of stitches, repeat the following two rows:

Row 1: Knit the first stitch, purl the next. Continue alternating between knit and purl stitches until you have just one stitch left, knit this stitch.

Row 2: Purl the first stitch, knit the next. Continue alternating between purl and knit stitches until you have just one stitch left, purl this stitch.

To work over an even number of stitches, only repeat row 1.

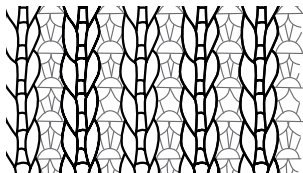

Adding a new ball of yarn / [▶ Online video tutorial](#)

When your ball of yarn runs out, or when you need to change the colour, tie a loose knot on to the tail with the new ball of yarn and slide it up to the needle. Tighten the knot. Continue knitting with the new yarn.

Right-leaning decrease / [▶ Online video tutorial](#)

Instead of knitting only one stitch at a time, knit two stitches together. Insert the front of your right needle through the first two stitches on the left needle, then knit them together as a single stitch.

Left-leaning purl decrease / [▶ Online video tutorial](#)

Insert the right needle through the next two stitches and purl them together as if they were a single stitch.

Left-leaning decrease / [Online video tutorial](#)

Insert the right needle into the next stitch on the left needle knit-wise (from left to right) and slip the stitch onto the right needle without knitting it. Slip the next stitch in the same way. Now insert the left needle through both these stitches, in front of the right needle, from left to right. Wrap the yarn as for a normal knit stitch and pull the yarn through both loops at once.

Right-leaning purl decrease / [Online video tutorial](#)

To make a right-leaning purl decrease, you purl two stitches together through the back of the loops. Holding the yarn ready to work a purl stitch, insert the right needle into the back of the second stitch on the left needle, from left to right (behind the left needle). Then continue by inserting the needle into the first stitch as well (from left to right as before). The right needle is now parallel to the left needle, with the right needle behind the left, and both needle tips pointing in the same direction. Wrap the yarn and complete the stitch as for a normal purl stitch.

Casting off / [Online video tutorial](#)

To complete your project, you need to cast off your last row of stitches in order to make an edge that won't unravel. For your final row, knit the first two stitches. Using the tip of the left needle, lift the first stitch up and over the second stitch and then slip it off the right needle. Now you have only one stitch on your right needle. Knit the next stitch from the left needle, then lift the previous stitch over it and off the needle as before. Do this with each stitch until there are no stitches on the left needle and just one stitch on the right needle. Cut the yarn, leaving a 15 cm/6" end. Pull on the last loop until the end pops through - you've now secured the last stitch.

Picking up stitches / [▶ Online video tutorial](#)

To pick up stitches along a cast-off edge, insert the right needle through the first cast-off stitch from front to back, taking care to catch both of the vertical yarn 'loops' at the top of the stitch. Wrap the yarn around the needle and pull through as for a normal knit stitch. Now do the same for the next stitch along the edge.

Sometimes it is necessary to pick up more or fewer stitches than the number of cast-off stitches along your edge - to do this, you can pick up two new stitches through the same cast-off stitch, or not pick up through all your cast-off stitches.

FINISHING TECHNIQUE

Vertical invisible seam / [▶ Online video tutorial](#)

This technique is used to join the side edges of two pieces. Place the two knitted pieces side by side with the right sides up.

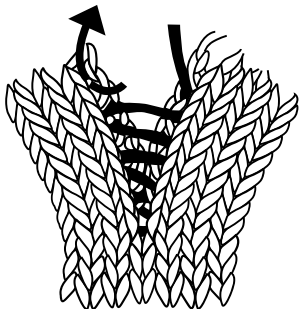

Insert your sewing needle under the first horizontal bar between the first two stitches on the edge you want to join. Pull the yarn through and insert the needle through the opposite horizontal bar on the other piece. Sew back and forth through the horizontal bars along the edge. To tighten the stitches, pull the yarn gently – and they will disappear.

Horizontal invisible seam technique / [Online video tutorial](#)

This technique is used for sewing together horizontal edges (like cast on and cast off edges). Align the two edges so that they are lined up stitch by stitch. Insert the sewing needle under a V stitch and then under the corresponding V stitch on the other side. Continue in this way until the seam is complete.

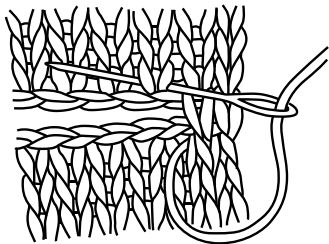

Weaving in the ends / [▶ Online video tutorial](#)

Weave the ends of your yarn into your knitting to finish it off and stop it from unravelling. Thread the tail end of yarn into the sewing needle. Weave the yarn through the stitches in the wrong side of the work, following the natural stitch direction created when the piece was knitted. Weave in approximately 10cm/4", then cut the tail.

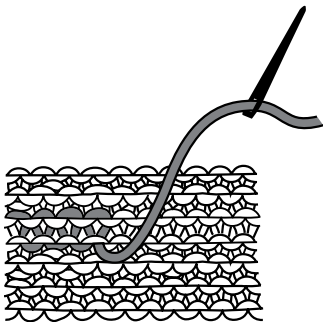

MAKING MEMOIRS

STARTED ON

FINISHED ON

WHERE I MADE IT

-

-

-

MADE FOR

Me

COLOUR COMBO

THIS PROJECT WAS

() easy peasy () nice () challenging () hardcore

I FEEL    

OTHER THOUGHTS

.....

NOTES

1"

2"

3"

4"

5"



5 CM

10 CM

YOUR PROJECT DESERVES SOME SEXY YARN

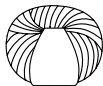

CRAZY SEXY WOOL

100% Peruvian Wool

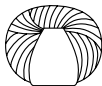

HEAL THE WOOL

100% Recycled Wool



LIL' HEAL THE WOOL

100% Recycled Wool



JERSEY BE GOOD

98% Cotton
2% Elastane



MIXTAPE YARN

80% Cotton
20% Polyester



BILLIE JEAN

100% Upcycled Denim



TAKE CARE MOHAIR

78% Kid Mohair
13% Wool / 9% Polyamide



FEELING GOOD

70% Baby Alpaca
7% Merino / 23% Nylon



SHINY HAPPY COTTON

100% Peruvian
Pima Cotton



SUGAR BABY ALPACA

100% Baby Alpaca



TINA TAPE YARN

100% Tencel®

WWW.WOOLANDTHEGANG.COM

**WOOL
AND THE
GANG**

V700164323

